

规格

设计
锻造阀体

连接
卡套连接/焊接/G螺纹/外螺纹
/NPT螺纹/RC螺纹

压力范围
1/8"-11/2"PN 250/350

温度范围
FPM: -20°C -+205°C

材料
阀体: A105
F304
F316

内件: 304
316

密封: FPM

Specification

DESIGN
Forging valve body

CONNECTION
Tube/Butt weld/G thread/Male thread
/NPT thread/RC thread

PRESSURE RANGE
1/8"-11/2"PN 250/350

TEMPERATURE RANGE
FPM: -20°C -+205°C

MATERIALS
Body: A105
F304
F316

Internal: 304
316

Seal: FPM

型号:
CER

高压单向阀
PN250/350

A105
F304
F316



Type:
CER

High-pressure check valve
PN250/350

A105
F304
F316

以上信息仅供参考，埃克美迅公司保留修改的权利，恕不另行通知

The above information is intended for guidance only and Eicmation company reserves the right to change any date herein without prior notice

举例说明: 比如 CER336AK10
 =高压单向阀, F304/304, FPM, PN350, 卡套, DN6
 单向阀

1. 字符 产品	2+3. 字符 阀体/ 内件	4. 字符 密封	5. 字符 标准压力	6. 字符 连接	7 + 8. 字符 口径 (仅限焊接/卡套)
CER=高压单向阀	23=A105/304 24=A105/316 33=F304/304 44=F316/316	6=FPM	9=PN250 A=PN350	1=G螺纹 8=NPT螺纹 K=卡套 S=焊接 R=RC螺纹 Y=外螺纹	10=1/8" 11=1/4" 12=3/8" 13=1/2" 14=3/4" 15=1" 16=1 1/4" 17=1 1/2"

Ordering example: e.g.CER336AK10
 =High-pressure check valve, F304/F304, FPM, PN350, Clamp, DN6
 Check valve

A. Product	B+C. Body/Internal	D. Seal	E. Pressure criteria	F. Connection	G+H. Size(Only weld/Clamp)
CER=High-pressure check valve	23=A105/304 24=A105/316 33=F304/304 44=F316/316	6=FPM	9=PN250 A=PN350	1=G Thread 8=NPT Thread K=Clamp S=Butt Weld R=RC Thread Y=Male Thread	10=1/8" 11=1/4" 12=3/8" 13=1/2" 14=3/4" 15=1" 16=1 1/4" 17=1 1/2"

尺寸/Dimension

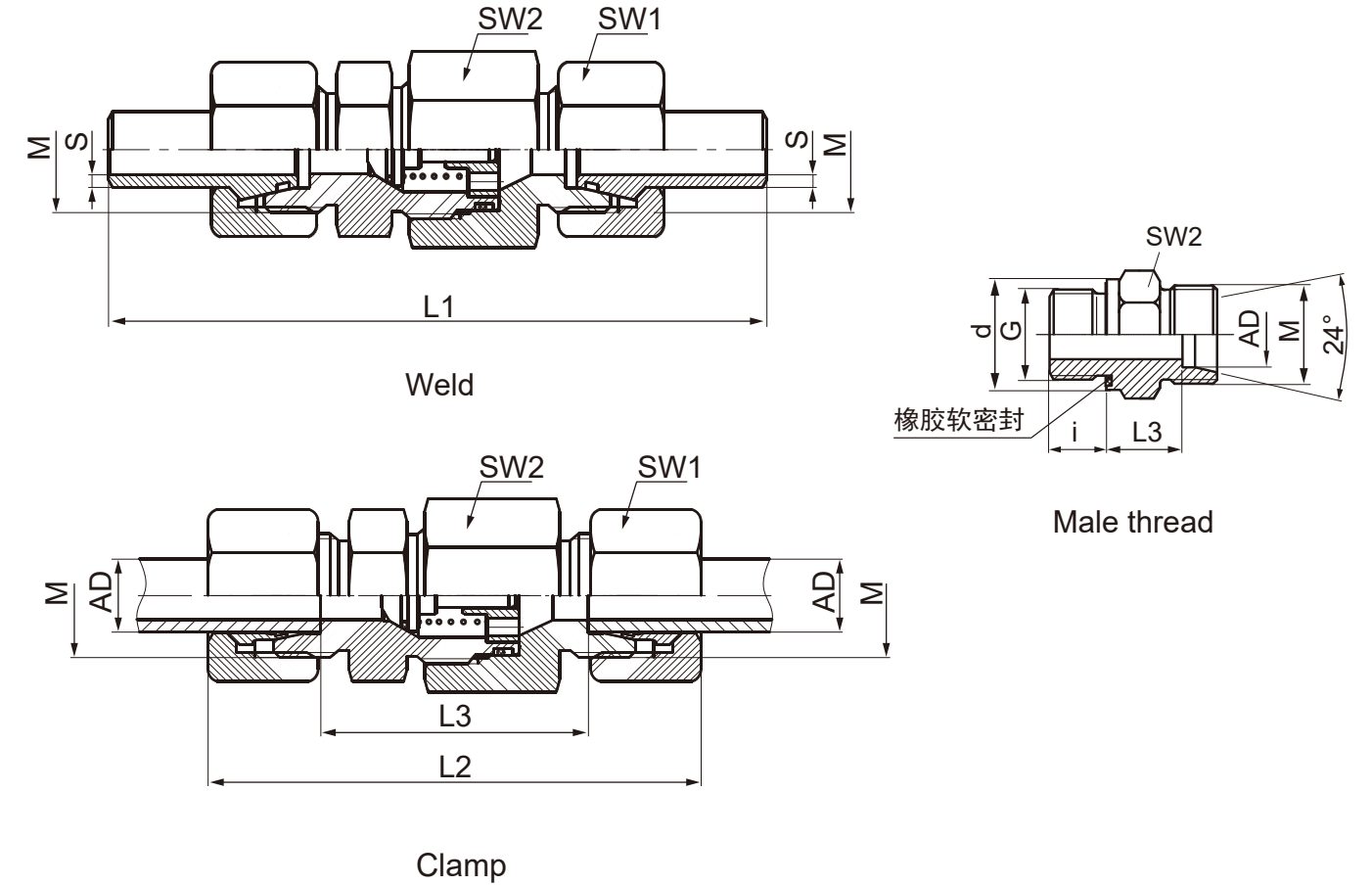

系列	SIZE	DN	S	G	d	L1	L2	L3	i	SW1	SW2	AD	M	PN
轻系列 L	1/8"	6	1.5	1/8"	14	90	57	27	8	14	19	6	M12X1.5	315
	1/4"	8	1.5	1/4"	19	90	57	27	12	17	22	8	M14X1.5	
	1/4"	10	1.5	1/4"	19	105	68	38	12	19	24	10	M16X1.5	
	3/8"	12	2	3/8"	22	105	68	38	12	22	24	12	M18X1.5	
	1/2"	15	2	1/2"	27	120	74	44	14	27	32	15	M22X1.5	
	1/2"	18	2.5	1/2"	27	122	76	43	14	32	32	18	M26X1.5	
	3/4"	22	3	3/4"	32	137	88	55	16	36	41	22	M30X2	250
	1"	28	4	1"	40	151	95	62	18	41	50	28	M36X2	
	1 1/4"	35	4	1 1/4"	50	176.5	117.5	74.5	20	50	60	35	M45X2	
重系列 S	1 1/2"	42	5	1 1/2"	55	178	120	74	22	60	65	42	M52X2	350
	1/2"	14	2	1/2"	27	122	78	42	14	27	24	14	M22X1.5	
	1/2"	16	2.5	1/2"	27	126	82	45	14	30	32	16	M24X1.5	315
	3/4"	20	3	3/4"	32	140	89	45	16	36	32	20	M30X2	
1"	25	4	1"	40	161	102	54	18	46	41	25	M36X2		

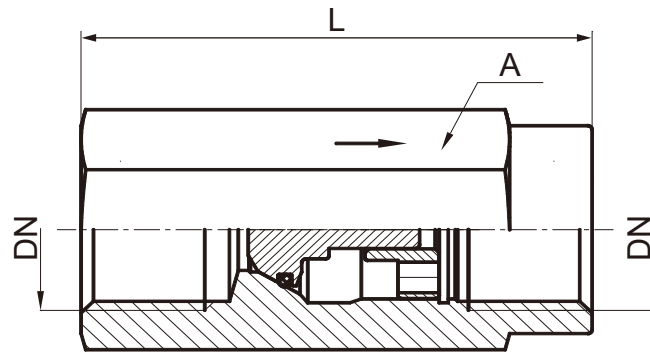

Thread

SIZE	DN	A	L	PN
G1/4"	5.5	19	50	350
G3/8"	8	22	58	
G1/2"	11	27	66	
G3/4"	14	36	78	300
G1"	19	41	93	
G1 1/4"	25	55	107	
G1 1/2"	30	60	120	210
RC1/4"	5.5	19	47	350
RC3/8"	8	22	55	
RC1/2"	11	27	62	
RC3/4"	14	36	73	300
RC1"	19	41	88	
RC1 1/4"	25	55	102	
RC1 1/2"	30	60	115	210
RC2"	38	70	122	160
1/4NPT	5.5	19	49	350
3/8NPT	8	22	57	
1/2NPT	11	27	64	