



规格

设计
精密铸造阀体，法兰式连接。

操作
顶部结构

连接
美标法兰
国标法兰

压力范围
PN16/PN25/PN40
150LB/300LB

公称压力
1/2" - 8": PN16/150LB/PN25/PN40/300LB

温度范围
-196°C - +570°C

材料
阀体: CF8
CF8M

阀板: 304
316

密封: 金属

填料: 柔性石墨

Specification

DESIGN
Precision cast valve body, flange connection.

OPERATION
Top type structure

CONNECTION
ANSI Flange
GB Flange

PRESSURE RANGE
PN16/PN25/PN40
150LB/300LB

NOMINAL PRESSURE
1/2" up to 8": PN16/150LB/PN25/PN40/300LB

TEMPERATURE RANGE
-196°C - +570°C

MATERIALS
Body: CF8
CF8M

Disc: 304
316

Seal: Metal

Spindle seal: Graphite

型号:
JBA/JBW
法兰截止阀/波纹管截止阀

PN16/PN25/PN40
150LB/300LB

CF8
CF8M



Type:
JBA/JBW
Flange globe valve/Bel-
lows globe valve

PN16/PN25/PN40
150LB/300LB

CF8
CF8M

举例说明: 比如 JBA33D4618

=法兰截止阀, CF8/304, 金属密封, PN25, 国标法兰, DN50
截止阀

1.字符 产品	2+3.字符 阀体/内件	4.字符 密封	5.字符 压力标准	6.字符 连接	7 + 8.字符 口径	
JBA=法兰截止阀 JBW=波纹管 法兰截止阀	34=CF8/316 33=CF8/304 44=CF8M/316	D=金属	3=PN16/150LB 4=PN25 5=PN40/300LB	6=国标法兰 M=美标法兰	13=1/2" 14=3/4" 15=1" 16=1-1/4" 17=1-1/2" 18=2"	19=2-1/2" 20=3" 21=4" 22=5" 23=6" 24=8"

Ordering example: e.g. JBA33D4618

= Flange globe valve, CF8/304, Metal, PN25, DIN Flange, DN50
Globe valve

A. Product	B+C. Body/Internal	D. Sealing	E. Pressure criteria	F. Connection	G+H. Size	
JBA= Flange globe valve JBW=Cast steel bellows flange globe valve	34=CF8/316 33=CF8/304 44=CF8M/316	D=Metal	3=PN16/150LB 4=PN25 5=PN40/300LB	6=GB Flange M=ASME Flange	13=1/2" 14=3/4" 15=1" 16=1-1/4" 17=1-1/2" 18=2"	19=2-1/2" 20=3" 21=4" 22=5" 23=6" 24=8"

以上信息仅供参考，本公司保留修改的权利，恕不另行通知

The above information is intended for guidance only and the company reserves the right to change any date herein without prior notice

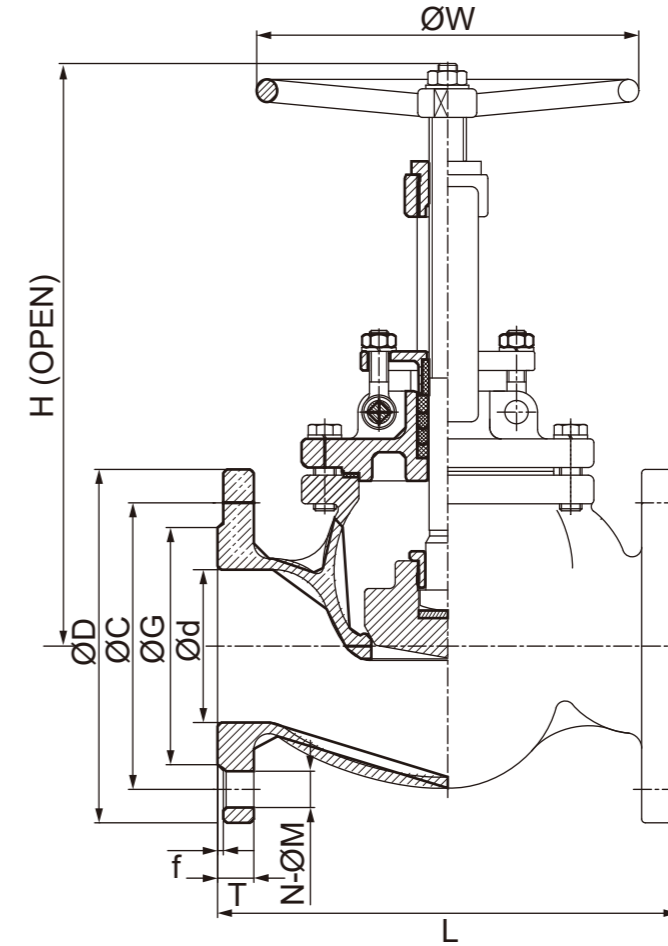
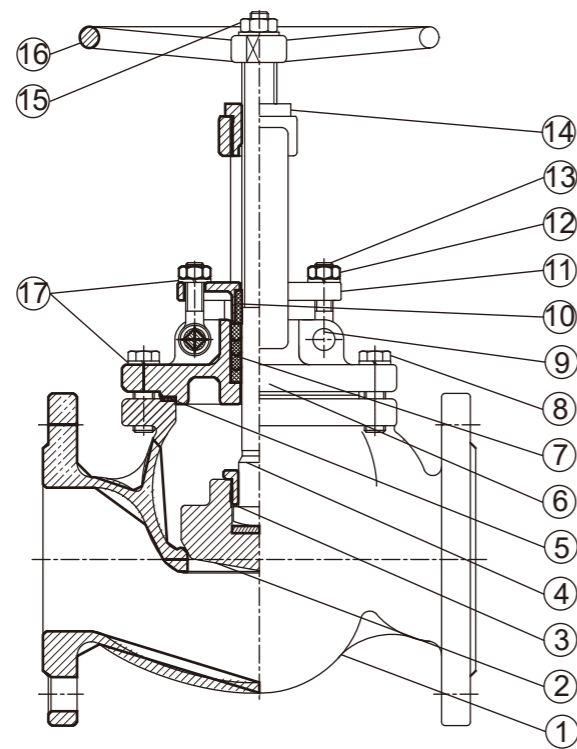

序号	描述	材质
1	阀体	CF8 CF8M
2	阀瓣	304 316
3	阀板盖	304 316
4	阀杆	304 316
5	垫片	304+柔性石墨
6	阀盖	CF8 CF8M
7	填料	柔性石墨
8	螺栓	B8 B8M
9	销	304 316
10	阀杆密封	柔性石墨
11	压盖	CF8
12	螺母	8
13	螺栓	B8
14	轴套	铜
15	螺母	8
16	手轮	球墨铸铁
17	弹垫	304

NO.	Description	Material
1	Body	CF8 CF8M
2	Disc	304 316
3	Disc cover	304 316
4	Stem	304 316
5	Gasket	304+Graphite
6	Cap	CF8 CF8M
7	Packing	Graphite
8	BOLT	B8 B8M
9	Hinge pin	304 316
10	Sleeve	Graphite
11	Gland	CF8
12	NUT	8
13	Eye Bolt	B8
14	Yoke sleeve	Bronze
15	NUT	8
16	Handle wheel	FCD400
17	Spring washer	304

SIZE	DN	Ød	L	PN16								PN25/40							
				ØW	H	ØD	ØC	ØG	f	T	N-ØM	ØW	H	ØD	ØC	ØG	f	T	N-ØM
1/2"	15	15	130	140	186	95	65	45	2	14	4-Ø14	140	230	95	65	45	2	16	4-Ø14
3/4"	20	20	150	140	181	105	75	58	2	16	4-Ø14	140	230	105	75	58	2	18	4-Ø14
1"	25	25	160	140	212	115	85	68	2	16	4-Ø14	140	230	115	85	68	2	18	4-Ø14
1-1/4"	32	32	180	160	243	140	100	78	2	16	4-Ø18	-	-	-	-	-	-	-	-
1-1/2"	40	40	200	160	236	150	110	88	3	16	4-Ø18	140	328	150	110	88	3	18	4-Ø18
2"	50	50	230	200	252	165	125	102	3	18	4-Ø18	250	378	165	125	102	3	20	4-Ø18
2-1/2"	65	65	290	200	308	185	145	122	3	18	4-Ø18	250	411	185	145	122	3	22	8-Ø18
3"	80	80	310	250	327	200	160	138	3	20	8-Ø18	300	426	200	160	138	3	24	8-Ø18
4"	100	100	350	250	384	220	180	158	3	20	8-Ø18	300	520	235	190	162	3	24	8-Ø22
5"	125	125	400	300	484	250	210	188	3	22	8-Ø18	-	-	-	-	-	-	-	-
6"	150	150	480	350	547	285	240	212	3	22	8-Ø22	450	667	300	250	218	3	28	8-Ø26
8"	200	200	600	350	669	340	295	268	3	24	12-Ø22	-	-	-	-	-	-	-	-

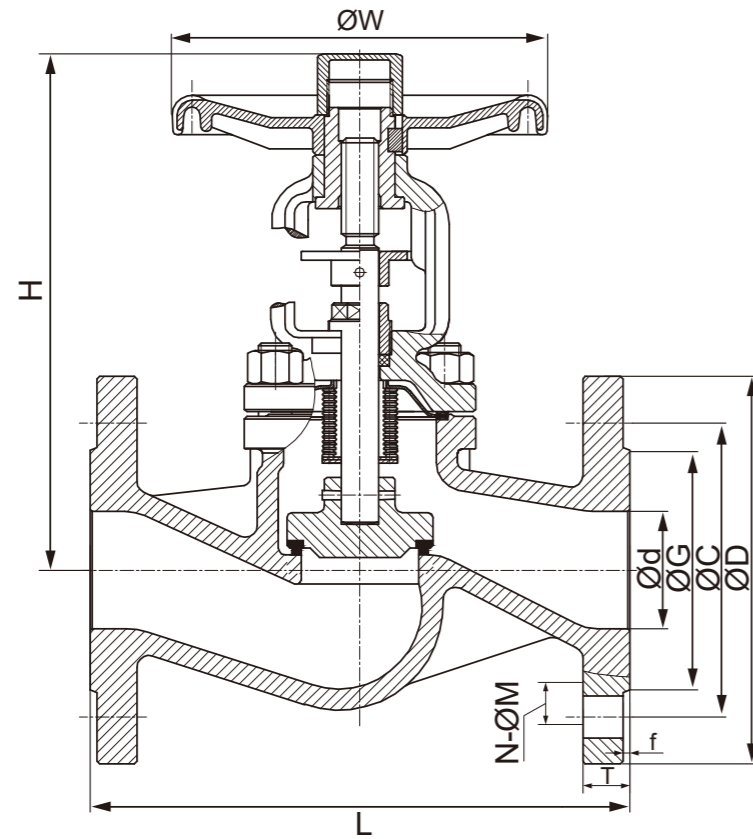

SIZE	DN	Ød	L	ØW	f	PN16					PN25					PN40							
						H	ØD	ØC	ØG	T	N-ØM	H	ØD	ØC	ØG	T	N-ØM	H	ØD	ØC	ØG	T	N-ØM
1/2"	15	15	130	120	2	190	95	65	45	16	4-14	190	95	65	45	16	4-14	190	95	65	45	16	4-14
3/4"	20	20	150	120	2	190	105	75	58	18	4-14	190	105	75	58	18	4-14	190	105	75	58	18	4-14
1"	25	25	160	140	2	195	115	85	68	18	4-14	195	115	85	68	18	4-14	195	115	85	68	18	4-14
1-1/4"	32	32	180	140	2	210	140	100	78	18	4-18	210	140	100	78	18	4-18	210	140	100	78	18	4-18
1-1/2"	40	40	200	160	2	220	150	110	88	18	4-18	220	150	110	88	18	4-18	220	150	110	88	18	4-18
2"	50	50	230	180	2	230	165	125	108	18	4-18	230	165	125	102	20	4-18	230	165	125	102	20	4-18
2-1/2"	65	65	290	180	2	255	185	145	122	18	8-18	255	185	145	122	22	8-18	255	185	145	122	22	8-18
3"	80	80	310	200	2	270	200	160	138	20	8-18	270	200	160	138	24	8-18	270	200	160	138	24	8-18
4"	100	100	350	250	2	360	220	180	158	20	8-18	360	235	190	162	24	8-22	360	235	190	162	24	8-22
5"	125	125	400	300	2	380	250	210	188	22	8-18	380	270	220	188	26	8-26	380	270	220	188	26	8-26
6"	150	150	480	300	2	415	285	240	212	22	8-22	427	300	250	218	28	8-26	436	300	250	218	28	8-26
8"	200	200	600	400	2	530	340	295	268	24	12-22	545	360	310	278	30	12-26	562	375	320	285	34	12-30
10"	250	250	730	520	2	665	405	355	320	26	12-26	675	425	370	335	32	12-30	683	450	385	345	38	12-33
12"	300	300	850	550	2	932	460	410	378	28	12-26	940	485	430	395	34	16-30	952	515	450	410	42	16-33
14"	350	350	980	600	2	992	520	470	428	30	16-26	1055	555	490	450	38	16-33	1065	580	510	465	46	16-36
16"	400	400	1100	650	2	1205	580	525	490	32	16-30	1213	620	550	505	40	16-36	1225	660	585	535	50	16-39

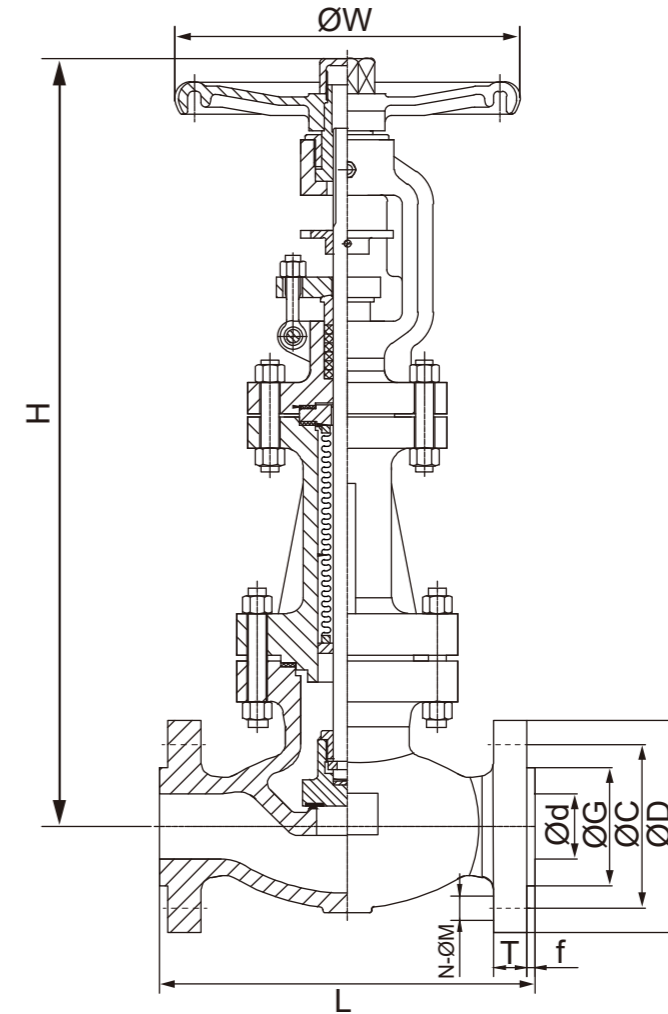

SIZE	DN	Ød	f	ØG	150LB							300LB						
					ØW	H	L	ØD	ØC	T	N-ØM	ØW	H	L	ØD	ØC	T	N-ØM
2"	50	50	2	92.1	200	348	203	150	120.7	17.5	4-16	200	356	267	165	127	20.7	8-16
2-1/2"	65	65	2	104.8	250	375	216	180	139.7	20.7	4-16	250	384	292	190	149.2	23.9	8-20
3"	80	80	2	127	250	385	241	190	152.4	22.3	4-16	250	440	318	210	168.3	27	8-20
4"	100	100	2	157.2	300	495	292	230	190.5	22.3	8-16	350	498	356	255	200	30.2	8-20
5"	125	125	2	185.7	300	552	356	255	215.9	22.3	8-20	400	575	400	280	235	33.4	8-20
6"	150	150	2	215.9	350	564	406	280	241.3	23.9	8-20	450	623	444	320	269.9	35	12-20
8"	200	200	2	269.9	400	590	495	345	298.5	27	8-20	580	937	559	380	330.2	39.7	12-24
10"	250	250	2	323.8	450	754	622	405	362	28.6	12-24	640	949	622	445	397.4	46.1	16-27
12"	300	300	2	381	640	941	698	485	431.8	30.2	12-24	640	995	711	520	450.8	49.3	16-30
14"	350	350	2	412.8	640	1085	787	535	476.3	33.4	12-27	-	-	-	585	514.4	52.4	20-30
16"	400	400	2	469.9	640	1296	914	595	539.8	35	16-27	-	-	-	650	571.5	55.6	20-33